

Sanitary Check Valve

卫生级止回阀

Product Information 产品信息

Check Valve is to prevent the fluid from flowing back and ensures to flow in only one direction. Check Valve open when the pressure of fluid exceeds the pressure to spring. When two pressure are equal, the valve automatic close.

止回阀是阻止流体回流的阀门，保证流体流向一个方向。止回阀开启当压力大于弹簧，但是当两边压力相同时，阀门会自动关闭。

- Working Temperature : -10°C to 120°C with EPDM gasket
工作温度: -10°C to 120°C
- Working Pressure : 10 Bar
工作压力: 10 Bar
- Steel Material: 304 / 316L
金属材料: 304/316L
- Seal Material: SILICON
密封圈材质: 硅胶
- Size: 1" to 4"
(other sizes available on request)



Check Valve-Weld End

止回阀-焊接

SMS

Size	A	B	C
1.0"	22.4	25.4	73.5
1.5"	35.0	38.1	76.5
2.0"	48.0	51.0	88.5
2.5"	59.4	63.5	102.5
3.0"	72.2	76.2	101.5
4.0"	97.6	101.6	109.0

Check Valve-Weld End

止回阀-焊接

DIN

Size	A	B	C
DN25	25.0	28.0	74.5
DN40	37.0	40.0	76.0
DN50	49.0	52.0	88.5
DN65	66.0	70.0	102.5
DN80	81.0	85.0	116.5
DN100	100.0	104.0	109.0

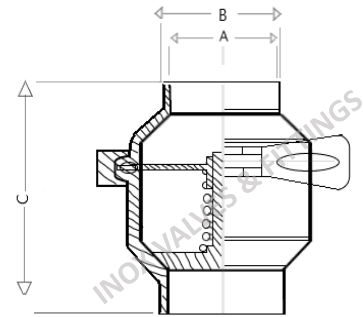

Check Valve-Ferrule End

止回阀-焊接

SMS

Size	A	B	C
1.0"	22.4	50.5	96.0
1.5"	35.0	50.5	95.0
2.0"	48.0	63.5	105.0
2.5"	59.4	76.2	115.0
3.0"	72.2	91.0	124.0
4.0"	97.6	119.0	137.0

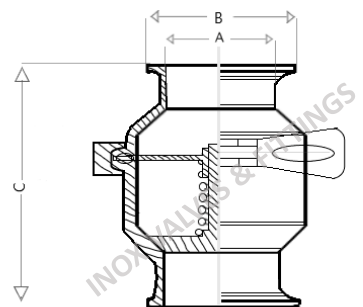

Check Valve-Ferrule End

止回阀-焊接

DIN

Size	A	B	C
DN25	25.0	50.5	114.0
DN40	37.0	50.5	114.0
DN50	49.0	63.5	128.0
DN65	66.0	91.0	146.0
DN80	81.0	85.0	156.0
DN100	100.0	119.0	162.0